



CONTROLLER MODERNIZATION FOR LOW AND MID-RISE ELEVATORS

KONE ReSolve™ 200 and 400

REVITALIZE YOUR ELEVATOR – IN JUST FIVE DAYS

All elevators need to be thoroughly modernized eventually – even if they have been properly maintained.

After about 10 years, parts wear out and repairs can become more expensive, and you might even have problems finding spares. If your elevator has been in service for 25 years or more, it's also likely that it isn't as reliable or safe as it could be.

Older elevators also use a lot more electricity than modern equipment and contain outdated technology. They might not level accurately with landing floors any more, which can cause people to trip or fall. An aging and unreliable elevator can even have an impact on the value of your building. After 25 years and 10,000 kilometers*, is it time to think about giving your elevator a new lease on life?

*Traction elevator, based on residential building usage of 25 years, 54,750 starts/year, 8 meters travel/start.

KEY BENEFITS

- Improves elevator energy efficiency, reliability, and safety
- Improves accessibility with accurate leveling
- Minimizes elevator downtime with quick installation
- Complies with all relevant EU safety and accessibility standards





SAVE MONEY AND IMPROVE SAFETY AND RELIABILITY AT THE SAME TIME

KONE ReSolve™ is a comprehensive controller modernization solution that can significantly cut your elevator's operating costs and also improve its reliability. With fewer repairs and much lower energy consumption, you can save a considerable amount of money over the elevator's lifetime.

KONE ReSolve also improves safety and accessibility by making sure your elevator levels accurately with landing floors, preventing people from tripping on the elevator sill.

PEACE OF MIND WITH INTELLIGENT SERVICES

Modernizing your elevator's electrification systems with KONE ReSolve means you can take advantage of KONE's 24/7 Connected Services to improve your elevator's performance, reliability, and safety. We analyze data from elevator sensors and make proactive decisions on how to solve potential problems – often before they even occur. These intelligent services give you peace of mind by keeping you fully informed about the condition of your equipment and any maintenance activities we carry out.

THE FAST AND FLEXIBLE WAY TO IMPROVE SAFETY, PERFORMANCE, AND ENERGY EFFICIENCY

We offer KONE ReSolve 200 for residential buildings and KONE ReSolve 400 for commercial buildings such as offices, hotels, and retail facilities. With both solutions we modernize your elevator's electrification system, specifically the controller. A KONE ReSolve modernization also brings peace of mind with an optional two-way KONE Remote Monitoring communication system that connects passengers with the nearest KONE Customer Care Center in the event of an emergency.

DURABLE COMPONENTS THAT LAST A LIFETIME

KONE ReSolve components are designed to be robust and reliable. The fully encapsulated circuit boards reduce the risk of electrostatic discharge and prevent dust and foreign objects from causing faults. The modernization also introduces a modern safety system that automatically identifies faults at the switch level. The system includes a graphical display to make it easier and faster for technicians to diagnose problems.

MORE FLEXIBILITY MEANS EASIER PLANNING

KONE ReSolve is suitable for modernizing the electrification systems of both traction and hydraulic elevators in buildings of up to 32 floors. For traction elevators, the solution provides flexibility in terms of planning and budgeting as the modernization can be carried out in two phases, replacing the electrification first and the hoisting system later.



The KONE ReSolve™ 400 controller cabinet

QUICK AND STRESS FREE INSTALLATION

The modernization work typically takes about 35 hours, or five working days. We'll assign a dedicated project manager who can provide more information, answer your questions, and make sure the project goes smoothly and efficiently. We do everything possible to minimize disturbance to everyday life in the building, and we also make sure that the materials left over from your old elevator equipment are recycled or disposed of responsibly.

SAVE POWER, SAVE MONEY

For traction elevators, KONE ReSolve uses Variable Voltage, Variable Frequency (V3F) drive control to significantly reduce energy consumption. For both traction and hydraulic elevators, you can make even greater energy savings with advanced standby features that power down certain functions when the elevator is not in use. KONE ReSolve 400 modernizations include a regenerative drive module for even greater energy savings.

	KONE ReSolve 200		KONE ReSolve 400
	Hydraulic	Traction	Traction
Speed (m/s)	0.1-1.0	0.3-1.0	1.0-2.5
Max. travel (m)	30	70	100
Max. floors	8	16	32
Max. elevators/ group	3	3	3
Max. starts/hour	120*	180	240
Typical starts/year	200,000	200,000	400,000
Drive system	Solenoid valve control	V ³ F	Regenerative V ³ F

*Power unit limitation may apply



KONE RESOLVE™ INCLUDES:

- 1 KONE ReSolve controller cabinet
- 2 Existing hoisting machinery
- 3 Positioning system
- 4 Door operator interface
- 5 Signalization
- 6 KONE Remote Monitoring (optional)

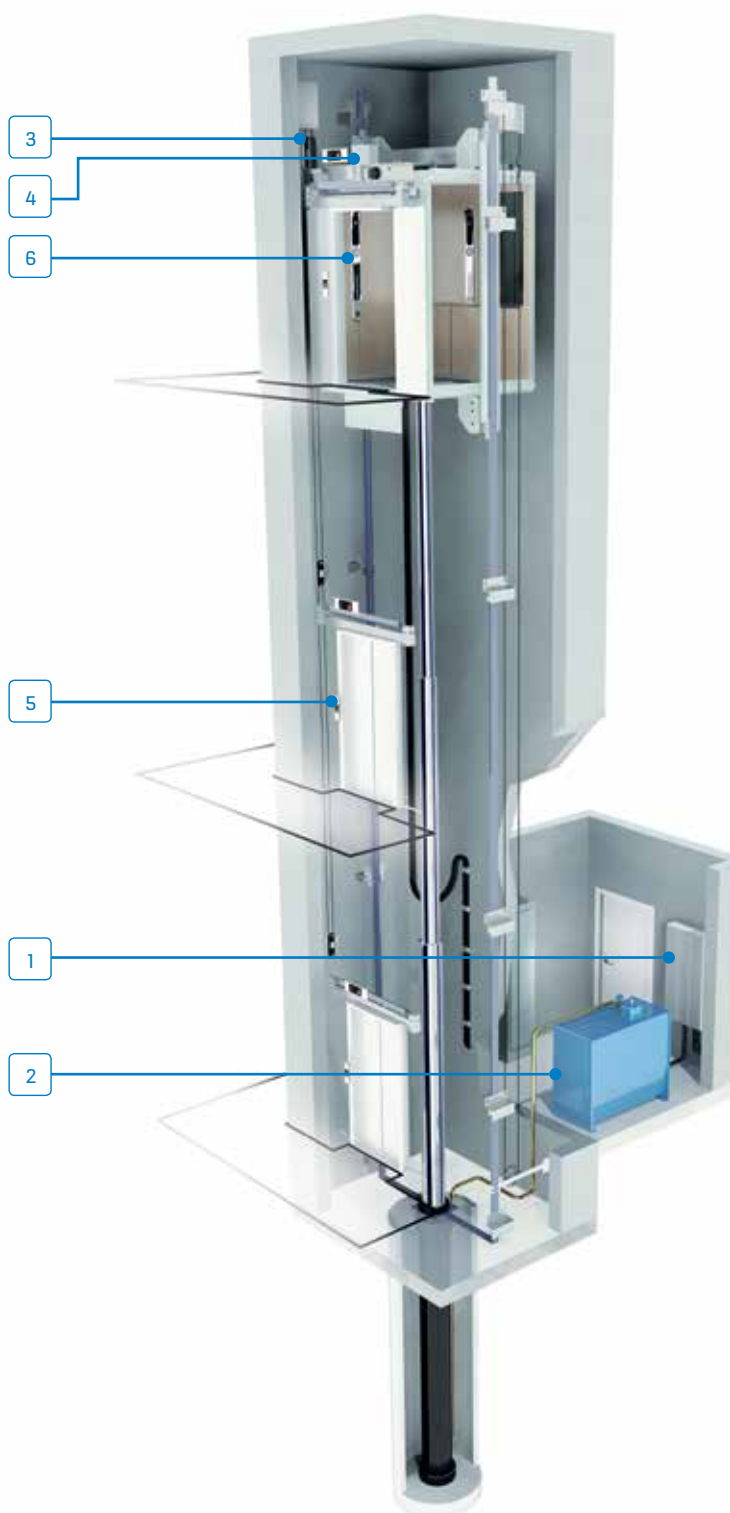

Hydraulic elevator modernization

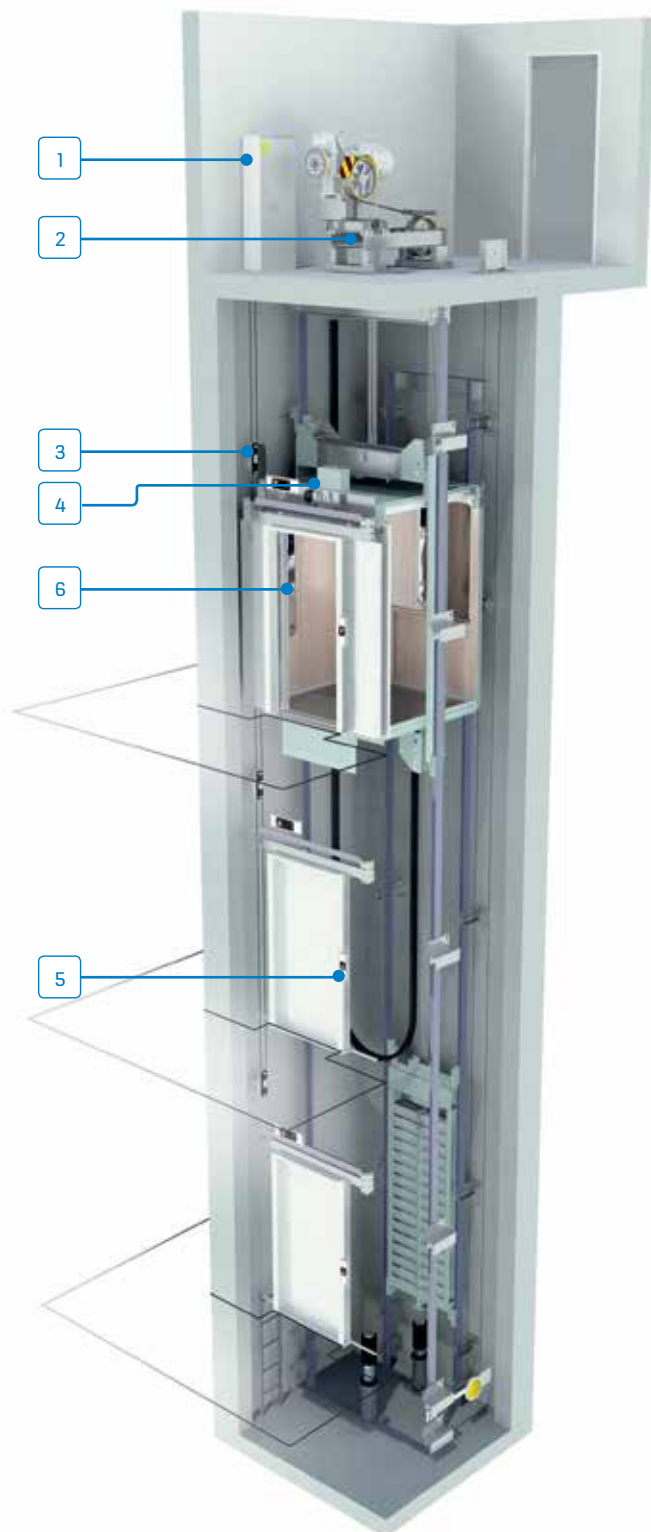

Traction elevator modernization

WE'RE WITH YOU EVERY STEP OF THE WAY

Modernizing an elevator with KONE ReSolve is simpler than you'd think, especially when we're there to help you through the entire process. To give you a better idea of what's involved, we've outlined the main ways that we help and support you at each step.

1

PLANNING

We can carry out a free-of-charge, no-obligation KONE Care for Life™ assessment to check the condition of your elevator and determine the best solution for your building. We'll assign a dedicated project manager who can provide more information, answer any questions, and make sure the project goes smoothly and efficiently.



2

SITE SURVEY

Before the modernization work begins, our project manager will conduct a site survey together with the building manager to finalize the site requirements. We make sure that everyone who uses the building is able to move around safely and that all permits, plans, and calculations have been checked and approved by the relevant local authorities. This is particularly important for smaller-scale modernizations in residential buildings.



4

COMPLETION AND HANDOVER

When the modernization work is complete, we perform final safety and performance inspections before handing over the elevator for use. With regular preventive maintenance carried out as part of a flexible KONE Care™ maintenance agreement, we make sure your equipment provides reliable service for its entire lifespan.



3

INSTALLATION

Our modernization process is designed to cause as little disruption as possible while the replacement work is completed. People can continue to live and work in the building with minimal impact on their daily activities. We protect floors, walls, and walkways to make sure they are not damaged, and make every effort to keep noise and dust to a minimum. Residents and tenants can stay up to date with the schedule and progress of the modernization work by checking the KONE InfoMod bulletin board in the lobby. We also make sure that the materials left over from your old elevator are recycled or disposed of responsibly.



KONE provides innovative and eco-efficient solutions for elevators, escalators, automatic building doors and the systems that integrate them with today's intelligent buildings.

We support our customers every step of the way; from design, manufacturing and installation to maintenance and modernization. KONE is a global leader in helping our customers manage the smooth flow of people and goods throughout their buildings.

Our commitment to customers is present in all KONE solutions. This makes us a reliable partner throughout the life cycle of the building. We challenge the conventional wisdom of the industry. We are fast, flexible, and we have a well-deserved reputation as a technology leader, with such innovations as KONE MonoSpace®, KONE NanoSpace™ and KONE UltraRope®.

KONE employs close to 52,000 dedicated experts to serve you globally and locally.

KONE CORPORATION

Head office

Kartanontie 1
P.O. Box 8
FI-00331 Helsinki
Finland
Tel. +358 (0)204 751

Corporate offices

Keilasatama 3
P.O. Box 7
FI-02151 Espoo
Finland
Tel. +358 (0)204 751

www.kone.com